

SPEEDZONE COMP CYCLOCOMPUTER

Congratulations on your purchase and welcome to the growing number of cyclists who are discovering a powerful new generation of bicycle computers. Your Specialized SpeedZone® Comp has been designed to provide the best combination of performance, features, durability and ease of use and installation.

The following functions are available on your SpeedZone Comp bicycle computer:

- SPD - Current Speed
- AVS - Average speed
- MAX - Maximum Speed
- ATM - Automatic Start/Timer
- DST - Trip Distance
- ODO - Odometer (total distance)
- ASI - +/- Average Speed Indicator
- TM - Stopwatch
- (Interval Timer) - Interval Timer
- Digital 12/24 Hour Clock
- Analog Clock



This computer also features:

- Second Wheel Option
- Easy calibration Mode
- Triple Display LCD
- Heavy-duty abrasion resistant pick-up wire
- Water resistant housing
- Two-year warranty

What is included in your SpeedZone Comp package:

1. SpeedZone Computer (1)
2. Mounting bracket (1)
3. Magnet with screw (1)
4. Cable tie wraps (4)
5. Mounting bracket sizing straps (3)

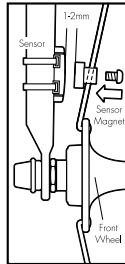
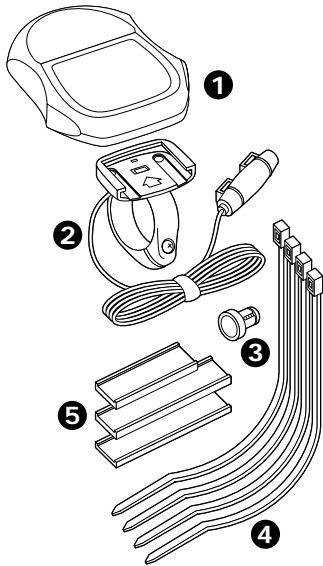

FIGURE 1:
SENSOR
PLACEMENT

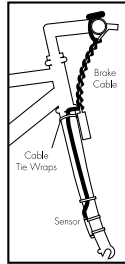

FIGURE 2:
MAGNET
ATTACHMENT

**MOUNTING
THE SPEEDZONE COMP**

The SpeedZone Comp sensor can mount on the right or the left side of the fork blade. Use the cable tie-wraps provided to position the sensor. Do not tighten until the final placement of the sensor magnet is correct. (See figure 1)

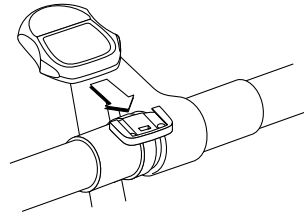

FIGURE 3: MOUNTING BRACKET

Attach the magnet to a spoke across from the sensor with the magnet screw. The clearance between the magnet and the sensor should be approximately 1/32"-1/16" (1-2mm). Tighten the magnet and transmitter. Do not over-tighten the magnet screw. (See figure 2.)

Attach the mount to the handlebar using the bracket screw provided. Tighten so that the bracket cannot rotate on the handlebar. There are several

sizing straps provided to fit different diameter bars. (See figure 3)

Slide the computer forward onto the mounting until it 'snaps' into place with an audible click. To remove the computer, push it backward until it releases from the mount. To test for proper installation of the magnet, sensor and computer, activate the computer by picking up the front of the bicycle and spinning the wheel. The "wheel option" indicator will flash. If it does not flash, check the sensor and magnet alignment. Realign as necessary until the "wheel option" indicator flashes while spinning the wheel.

PROGRAMMING

Programming the functions of your SpeedZone Comp requires it to be placed in various "modes" (i.e.

odometer mode, distance mode). The computer can be cycled through these modes by pressing the "MODE" button located on the right-hand side of the housing. Once a specific mode has been entered, its values can be reset or adjusted by pressing either the "FUNCTION" button located on the left hand side of the housing or by using a combination of the "MODE" and "FUNCTION" buttons.

1. Miles or Kilometers selection

Your SpeedZone Comp will record speed and distance in either miles (M/h) or kilometers (Km/h). To enter your selection of miles or kilometers, push the "MODE" button until ODO (odometer) appears in the lower left side of the display (This is called the odometer mode). Hold down the

"FUNCTION" (left side) button and 'tap' the "MODE" button once. The Km/h, m/h indicator will begin blinking. You may now alternate between miles and kilometers by pressing the "MODE" button. When the correct choice is flashing, select it by pressing the "FUNCTION" button. You will now enter the "Programmable Odometer" mode. If the odometer setting is correct push the "FUNCTION" button five times to exit odometer mode. (Otherwise, see "Setting the Programmable Odometer" below).

2. Setting the Programmable Odometer

To access the programmable odometer mode, first advance the "MODE" button until (ODO) appears on the left-hand side of the screen. Then hold

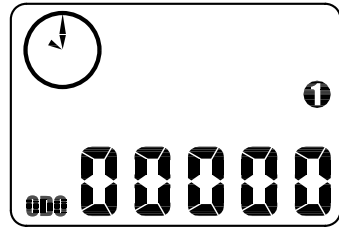

FIGURE 4: PROGRAMMABLE ODOMETER SCREEN

down the "FUNCTION" button and 'tap' the "MODE" button once. (See figure 4) The Km/h indicator will flash. If the Km/h setting is correct press the "FUNCTION" button once and a five-digit number will appear. You are now in the programmable odometer mode. This mode is useful if you have replaced the battery and would like to retain the mileage you have already

ridden. To enter a mileage into the odometer, press the "MODE" button until the flashing digit is correct. (Note: The "MODE" button may be held to scroll to the correct digit.) Press the "FUNCTION" button to select the next digit to the right. Repeat this process until all five digits are entered as your existing mileage.

3. Wheel Circumference Selection

To set the circumference for the type of tires you are using, you can use Specialized's exclusive "Easy Calibration Mode" or measure your actual tire circumference by the rollout method. Two different tire diameters may be entered into the computer's "Second Wheel Option."

Easy Calibration Mode:

Your SpeedZone Comp has been preprogrammed with the following

14 Specialized tire sizes:

26 X 1.0	26 X 2.2
26 X 1.25	650c X 20
26 X 1.5	700c X 20
26 X 1.95	700c X 23
26 X 1.9	700c X 26
26 X 2.0	700c X 32
26 X 2.1	700c X 38

When using Easy Calibration Mode, the SpeedZone will display the tire size on its LCD display screen. (See figure 5) The Easy Calibration Mode is accessed by entering the odometer (ODO) mode and holding down the "FUNCTION" button for three seconds. The display will now show the currently

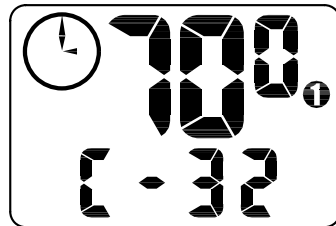

FIGURE 5: EASY CALIBRATION SCREEN

selected tire size for wheel option #1. To scroll through the preprogrammed tire sizes, tap both the "MODE" and "FUNCTION" buttons simultaneously. When you reach the desired tire size press the "FUNCTION" button once to select it and enter Easy Calibration Mode for wheel option #2. Follow the same procedure to program the wheel

#2 tire size and tap the "FUNCTION" button to exit easy calibration mode.

Roll Out Method

The roll out method will provide the most accurate computer calibration and can take into account variables such as inflation pressure, rim width and rider weight.

1. Extend a tape measure out to 3000mm (120 inches) and lock it in place.
2. With your tire inflated to its proper pressure, place the valve at the 6:00 position (at the bottom) directly over the start of the measuring tape.
3. Roll the wheel one complete revolution until the valve stem is again at the 6:00 position. Read the tape directly under the valve and note the distance in millimeters. (To con-

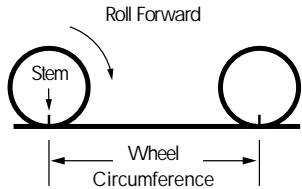

FIGURE 6: ROLL OUT METHOD

vert inches to millimeters, multiply inches by 25.4). Use this number to replace the default (default values are 2073 for wheel one, and 2134 for wheel two) when programming your computer. (See figure 6)

You may also use the following quick-reference chart:

Generic Tire Size Chart
(This chart is for non-specialized tires)

26 X 1.75	2140
26 X 2.0	2074
26 X 2.1	2090
650C X 20	1945
700C X 26	2124
700C X 38	2170

Programming the circumference:

To enter the tire circumference number, select the odometer (ODO) mode and hold down the "FUNCTION" button for three seconds. The display will now show the currently selected tire size for wheel option #1. (See figure 7) If necessary scroll through the pre-programmed tire sizes by tapping both

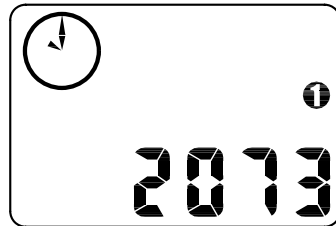

FIGURE 7: CIRCUMFERENCE PROGRAMMING SCREEN

the "MODE" and "FUNCTION" buttons simultaneously until the display shows a four-digit number. This number represents your tire circumference in millimeters. Press the "MODE" button until the flashing digit is correct. (Note: The "MODE" button may be held to scroll to the correct digit.) Press the "FUNCTION" button to select the next

digit to the right. Repeat the process until all four digits are entered as your tire circumference. Press the "FUNCTION" button once to select it and enter the circumference for wheel option #2. Follow the same procedure to program the wheel #2 tire size and tap the "FUNCTION" button to exit circumference programming mode.

4. Setting the Clock

Your SpeedZone Comp features two clocks, one analog and one digital. The hands of the analog clock will be set automatically to correspond to the digital one. To access the "clock mode" press and hold the "MODE" button for three seconds. To set the clock, press the "FUNCTION" button for three seconds. The display will flash either twelve (12:) or twenty-four (24:).

Select between 12: or 24: mode by pressing the "MODE" button. Press the "FUNCTION" button to set the mode.

The hour digit will now begin flashing. Press the "MODE" button to adjust the hour digits and press the "FUNCTION" button to set. The minutes will flash and can be adjusted by pressing the "MODE" button. (Hold the "MODE" button to scroll through the digits quickly) Press the "FUNCTION" button to set the minutes and return to clock mode

Note: The minute hand of the analog clock has twelve segments and can only display time in five-minute increments. The hand will not jump to the next segment until the digital clock reaches whole five-minute intervals. (e.g., 12:05, 12:10, 12:15, etc.) (See figure 8)

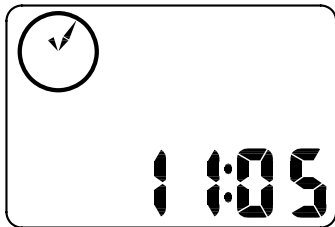

FIGURE 8: SHOW CLOCK SCREEN

5. Timer Selection

The timer can be selected for either Automatic Timer Mode (ATM) or Timer Mode (TM). The ATM selection allows you to keep track of your actual riding time. The timer only operates when the wheel is rotating and cannot be turned on or off manually.

The TM selection is just like a conventional stopwatch. The timer is activated

manually and records the time whether the wheel is rotating or not. Tapping the "FUNCTION" button starts and stops the stopwatch and holding the "FUNCTION" button for three seconds will reset to stopwatch.

Note: The average speed (AVS) will be calculated differently based upon the selection of ATM or TM. If ATM is selected, the AVS is based upon only

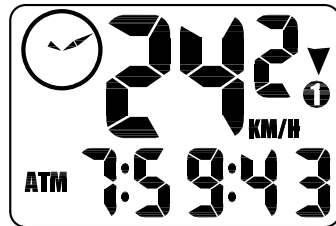

FIGURE 9: ATM/TM SCREEN

riding time. If TM is selected the AVS is based on the total time the stopwatch is turned on or activated. (See figure 9)

To select between ATM and TM, first press the "MODE" button until "ATM" appears on the left-hand side of the screen. Then press and hold the "FUNCTION" and tap the "MODE" button. Either ATM or TM will flash. Press the "MODE" button to select between the two modes and press "FUNCTION" to return to normal operating mode.

6. Interval Timer

Your Speedzone Comp is also equipped with an Interval Timer. This feature allows you to customize your training by integrating a programmable repeating countdown timer into your workout. To enter the interval

timer mode, press the "MODE" button until the hourglass appears on the left-hand side of the screen. You are now in interval timer mode. To set the interval timer, hold the "FUNCTION" button for three seconds. The hour digit will begin flashing. Press the "MODE" Button until the desired number appears. Press the "FUNCTION" button once to set this number and advance to minutes. Repeat this process until minutes and seconds are set to the desired settings. Press the "FUNCTION" button to exit programming mode. Once the interval timer is programmed, press the "FUNCTION" button to start/stop the countdown. (See figure 10)

Note: The shortest interval that can be set is 5 seconds.

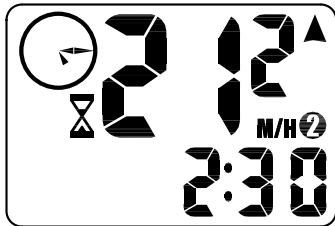

FIGURE 10: INTERVAL TIMER SCREEN

COMPUTER FUNCTIONS

Speedometer

Speed is always indicated on the top line of the screen. The speed is shown continuously up to 99.9 M/h (99.9 Km/h) with a resolution of 0.1 M/h (0.1 Km/h)

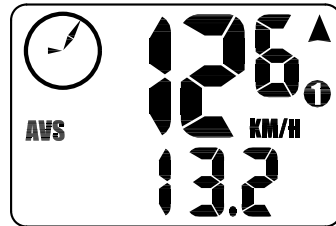

FIGURE 11: AVERAGE SPEED SCREEN

Average Speed (AVS)

The average speed is displayed on the lower line of the screen when AVS is shown on the left. The average speed is based upon whether the ATM or the TM mode has been selected, the resolution of the average speed is shown in 0.1M/h or Km/h increments. (See figure 11)

+/- Average Speed Indicator

An up or down arrow displayed in the upper right side of the screen shows whether the current speed is above or below the average speed. The arrow is always displayed so you know if you're maintaining your average speed while in another mode.

Maximum Speed (MXS)

The maximum speed is displayed on the lower line of the screen when MXS is shown on the left. The maximum speed is retained in memory and updated when a higher speed is attained. The maximum speed can be reset by pressing the "FUNCTION" button for three seconds. (See figure 12)

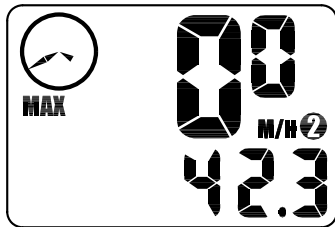

FIGURE 12: MAXIMUM SPEED SCREEN

Auto Start/Stop Timer (ATM)

The stop watch function will operate only when there is speed input and records the actual time spent riding. Pressing the "FUNCTION" button for 3 seconds will reset the ATM display to zero.

Timer Mode (TM)

In TM mode the stopwatch function will operate when the "FUNCTION" button

is pressed. The stopwatch will record the total time after the button is pressed regardless of whether there is speed input or not. The average speed (AVS) will be calculated based on the time the timer mode is activated.

Interval Timer (hourglass icon)

The interval timer will display on the lower line of the screen when the hourglass appears on the left. The timer will indicate you are reaching the end of a cycle with one beep per second for the last 5 seconds of an interval. This is followed by a continuous three-second beep as the interval timer repeats.

Trip Distance (DST)

Trip distance mode will record up to 999.99 miles or kilometers and then roll to zero. The trip distance function can

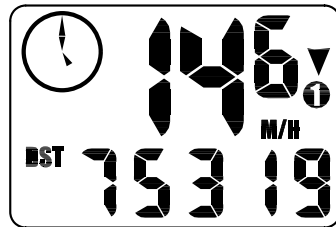

FIGURE 13: TRIP DISTANCE SCREEN

be reset by pressing the "FUNCTION" button for three seconds. The resolution is 0.01 miles (0.01 Kilometers). The trip distance is shown on the lower line of the screen. (See figure 13)

Odometer (ODO)

The odometer will record the total distance traveled up to 99,999 miles

or kilometers and then roll to zero. The odometer can be reset by pressing the "FUNCTION" button for three seconds. The total distance is shown on the lower line if the screen. (See figure 14)

Programmable Odometer

The odometer digits are user settable. This is convenient for transferring your hard-earned mileage that is usually

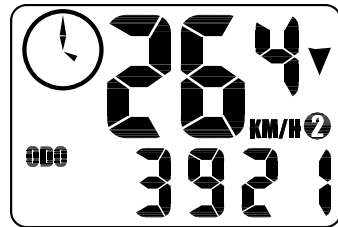

FIGURE 14: ODOMETER SCREEN

lost when changing batteries or computers.

Clock

The SpeedZone Comp has two clocks, one digital and one analog. The digital clock is accessed by pressing the "MODE" button for three seconds. There is an option of either 12 hour or 24 hour clock settings and is shown on the lower line of the screen. The analog clock is always displayed in the upper right side of the screen. The minute hand of the analog clock has twelve segments and can only display time in five-minute increments. The hand will not jump to the next segment until the digital clock reaches whole five-minute intervals.

Second Wheel Mode

For riders who own more than one bicycle or who frequently change tires, the SpeedZone Comp is capable of storing two tire sizes. You can change between the two sized by pressing both the "MODE" and "FUNCTION" buttons simultaneously for three seconds. The second wheel mode indicator will change from 1 to 2. Mileage recorded will be cumulative between the two sizes. (An additional handlebar mount is available from your Specialized dealer)

Triple Display LCD

The display screen on your SpeedZone Comp can provide three pieces of information simultaneously: Current Speed (always displayed on the top

line of the screen), Current Time (on analog clock), and your choice of one of the following: Average Speed, Maximum Speed, Current Time (digital clock), Trip Distance, Interval Timer or Odometer.

INSTALLING THE BATTERY

Should you need to replace the battery, push the computer backward to remove it from the handlebar mount. Before removing the battery make a note of your odometer reading and wheel circumference settings so that you can re-enter them when you restart the computer. Turn the computer over so the display is facing downward. Use a coin to unthread the battery cap from the computer. Install the battery (model CR2302) with the positive pole (+) facing upward. Carefully

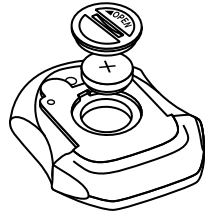

FIGURE 15: BATTERY INSTALLATION

thread the battery cap back onto the case with a coin. (See Figure 15)

If the LCD display is blank or shows incomplete digits, turn the computer over and press the "AC" button on the bottom of the case with the tip of a pen or a paper clip. This will clear all the data and re-start the computer. Reinstall the computer by pushing it forward into the mount until it snaps into place.

TROUBLESHOOTING

- *Display is blank:*
Change the battery or press the AC button on the bottom of the case
- *Display shows partial digits:*
Press the AC button on the bottom of the case.
- *Speed/distance not recording:*
Check sensor/magnet alignment.
Make sure that the sensor is no more than 1/16" (2mm) from the magnet.
- *Entire screen is dark:*
Did you leave the bike parked in the hot direct sun when it was parked? If so, move the bike to the shade. The data will be OK.
- *Computer moves on handlebar:*
Tighten mount or add sizing straps to improve fit on handlebar.

IMPORTANT!

- Pay attention to traffic and road conditions at all times. Your first obligation is to be attentive and to ride safely.
- Keep your computer in good shape and use it safely.
- Do not expose it to direct sunlight except when you are riding.
- Do not disassemble it.
- Make sure the magnet and the transmitter are well aligned. Check them regularly.
- Keep the computer and all of its components tightly attached, and check them regularly. If any of the components come loose, it could become tangled in your spokes and cause an accident.

- See your authorized Specialized dealer if you have any trouble installing or maintaining your computer.
- Clean the unit with a mild detergent and a soft dry cloth. Never use any kind of solvent or alcohol.
- The SpeedZone Comp computer is intended for use on bicycles only and should not be used on any motorized vehicle.

WARRANTY INFORMATION

Specialized cycling computers are guaranteed to be free from defects in materials and/or workmanship (excluding battery) for a period of two years from the date of purchase. Specialized will at its option, repair or replace your defective computer.

To receive warranty service send the unit, a copy of the sales receipt and a brief description of the problem to:

Specialized Bicycle Components Inc.
15130 Concord Circle
Morgan Hill, CA. 95037
*Attn: Product Services/
Computer Warranty*

SPECIFICATIONS

Current Speed

0.0 to 99.9 MPH

0.0 to 99.9 Km/H

Average Speed (AVS)

0.0 to 199.9 MPH

0.0 to 199.9 Km/H

Maximum Speed (MXS)

0.0 to 199.9 MPH

0.0 to 199.9 Km/H

Stopwatch (TM)

0 to 9hrs, 59min, 59sec. recycling type

Automatic Timer (ATM)

0 to 9hrs, 59min, 59sec. recycling type

Interval Timer (icon)

5 seconds to 9hrs, 59 min, 59 sec.

Trip Distance (DST)

0 to 999.99 miles or Km

Odometer (ODO)

0 to 99,999 miles or Km

Operating Temperature

40°F to 104°F (4°C to 40°C)

SpeedZone is a registered trademark
of Specialized Bicycle Components Inc.
© 1998 Specialized Bicycle Components Inc.